

type number	for width of cable tray (mm)	thickness of metal sheet (mm)	weight (kg/pc)	amount of bolts for connection (pc)	
SU 35_S	35	1	0,23	4	
SU 35_GMT			0,27		
SU 60_S	60	1	0,30	🔥🔥	
SU 60_GMT			0,34	4	🔥🔥
SU 60_ZM			0,30		🔥🔥
SU 85_S	85	1	0,36	8	
SU 85_GMT			0,42		
SU 110_S	110	1	0,44	🔥	
SU 110_GMT			0,51	🔥	

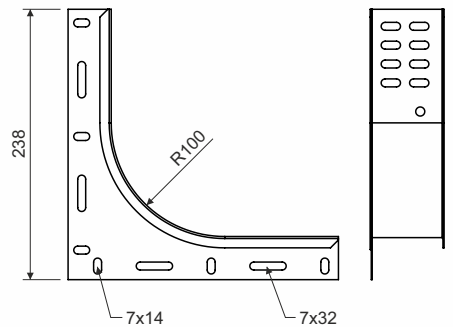
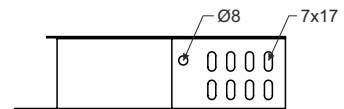

product description: It is used for making an additional branching use an unequal T-piece or cross.
 Advantage of this using is availability to choose bending tray with any width.
 The reduction piece is delivered in singles, must be used 2 pieces for installation.
 The connection is performed using the bolts NSM 6X10. To protect the cables, the bolt head is inside the cable tray.
 A bolt with a GMT surface finish is used for a tray with F and ZM surface finish.
 These items can also be ordered in a varnished version.

surface finish: S - Pre-Galvanized according to EN 10346, EN 10143, zinc-layer 15-27 µm
 F - Hot Dip Galvanized according to ČSN EN ISO 1461, zinc-layer 45 µm (min. 35 µm)
 ZM - galvanized steel with admixture of magnesium and aluminum according to EN 10346, EN 10143, protective layer 18-31 µm

sales amount: 1 pc

meets the requirements: ČSN EN 61537:02

classification: ČSN 73 0895 P 90-R
 DIN 4102-12 E 90
 STN 92 0205 PS 90
 Fire classification is depend on the specific conditions of the cable tray, detailed in the catalog Systems with maintained functionality in fire
 🔥 products approved for standard constructions
 🔥 products approved for non-standard constructions

storage: ČSN EN 60721-3-1

length of cut out side wall of the tray for branch	width of cable tray D
50	250
100	300
150	350
200	400
300	500
400	600
500	700
600	800

